

IQ Series-200 & 400

Multi-Configurable Two—Twelve Door Access Controller

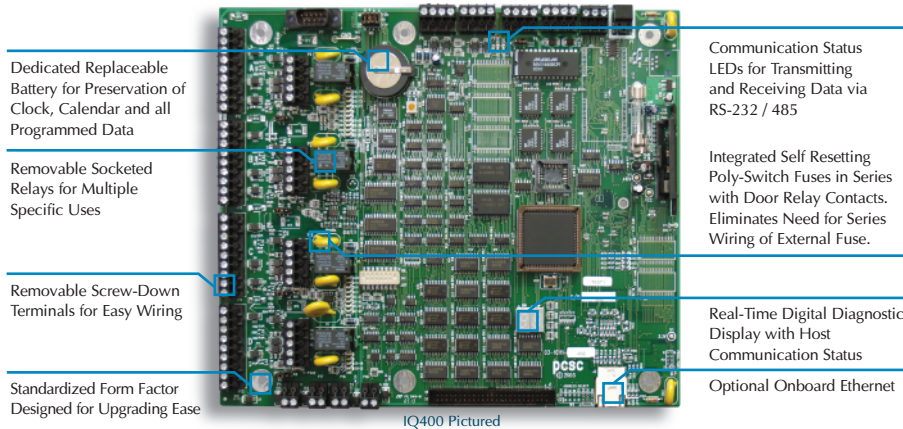

The **IQ Series** controllers are PCSC's benchmark for access control, input and output control monitoring. System configuration begins with either a two door controller (IQ 200) or a four door controller (IQ 400). Each controller can be expanded in 4 reader increments, up to 10 or 12 readers. Modular upgrades with add-on readers, inputs and outputs are engineered into the IQ Series design enabling you to dynamically configure a custom security system with standard off the shelf components.

Each system configuration provides 100% Distributed Intelligence (DI). PCSC's DI guarantees complete integrity of the security features even during a loss of communication to the host. All pertinent data necessary to make card access decisions and input/output decisions are stored in the controller and saved in the battery backed up memory for over one year. Additional features provide user applications for simple to high security environments. Basic card authorization is based on reader, time of day, day of week and holiday control. User activation can enable secondary or affiliation group authentication logics. Increased security features include Escort Required, Two Person Minimum Occupancy, Supervisory Control and 5 State Supervised Alarm Monitoring.

The PCSC "Upgrade Bus" was the first modular architecture allowing an upgrade to higher capacity CPUs in the PCSC controller family. The "Plug and Play" methodology provides an easy, cost effective upgrade path for replacing an aging TIP, MTIP or a MicroLPM series controller.

Capacities

- 2, 4, 6, 8, 10 or 12 Reader Configurations*
- 8,000 to 20,000 or 50,000 Cardholders*
- 4,000 to 10,000 History Transactions*
- 16 site codes
- 4 Authorization Groups per Cardholder
- 4 MB Max Capacity SRAM for Cardholders
- 64 Time Periods with 7 Segments Per Period
- 366 Holidays (Leap Year)
- 1 Yr. Battery Backed Clock Calendar and Memory
- Optional Universal Power Supply (90-250 VAC)

*Note: Certain capacities and configurations are dependent on IQ 200 or IQ 400.

Features

- 16-Bit High-Integration Embedded Intel® Processor (80C188EB-20)
- Legacy Upgrade Capable
- 100% Distributed Intelligence
- Open Architecture
- Handicapped Access
- Automatic Card Deactivation by Date
- Card Action
- User Specified Supervised or Digital Sense Input Definition
- High Security 5 State Alarm Supervision
- User Programmable Input/Output Logic
- Supervisory Access Authorization Logic
- Two Person Minimum Occupancy Rule (TPMOR)
- 3 Tier Anti-Passback
- Supervised Readers
- Electronic Firmware Updates (Flash Memory)
- Real-time Diagnostics
- AC Power Fail Indication
- DC Power Low Indication
- UL 294, 1076, AUSTEL and CE Listed

Reader Technologies Supported

- Proximity
- Smart Card
- Magnetic Stripe
- Keypad
- Biometric

Communications Supported

- RS485 or RS 232
- Leased Line
- Wireless
- Fiber Optics
- 10/100 TCP/IP Ethernet (optional)
- DHCP (IQ400 only)

Commitment to Excellence

All PCSC products allow full forward and backward compatibility. Intermixing is also capable with the Ultimate™ Series, IQ™ Series and SIM™ Series controllers. In addition, all products are backed by our commitment for complete customer satisfaction.

DOOR ACCESS CONTROLLER

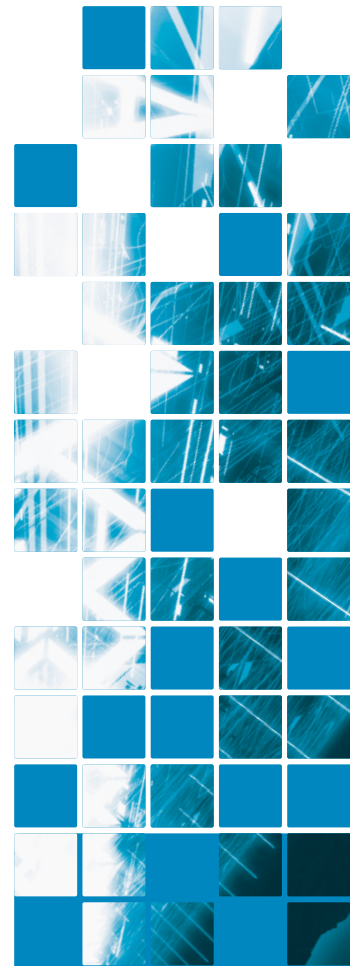

LOGICAL
INTELLIGENT
NETWORK
CONTROLLERS

PCSC

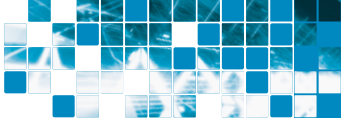

Optional Upgrades	Model# IQ200	Model# IQ400
Cardholder Capacity up to:	20,000 or 24,000	50,000
Universal Power Supply with Charger	P3 or P6	P6
24 VDC Input (12 VDC Standard)	24	24
Enclosure	M or L	L
Rear Panel	R	R

Specifications

Relay Rating: Form C 2.0 Amps @24 VDC
Environmental: 32° -115° F (0° - 46° C)
Humidity: 0 - 90% Non-Condensing

Enclosure Dimensions

16 AWG CRS enclosure with Tamper, Lock, and Key
Medium: 18"h x 11.5"w x 6"d (45.7 cm x 29.2 cm x 15.2cm)
Large: 21.6"h x 16.1"w x 5.7"d (55.4 cm x 40.9 cm x 14.5 cm)

IQ Series Configurations:

System configuration begins with either a two door controller (IQ 200) or a four door controller (IQ 400). Each controller can be expanded in 4 reader increments, up to 10 or 12 readers.

Model	Optional TCP/IP Comm. (LAN)	Reader Ports	Door Lock Relay	Door Status Supervised Input	Supervised Request To Exit	Supervised Readers	Additional Supervised Inputs	Voltage Outputs	Enclosure Tamper	Upgrade Capable	Max Power Amps@12VDC
IQ20	YES	2	2	2	2	2	5	4	1	N/A	260mA
IQ200	YES	2	2	2	2	2	5	4	1	YES	260mA
IQ600	YES	6	6	6	6	6	5	8	1	YES	710mA
IQ400	YES	4	4	4	4	4	5	6	1	YES	340mA
IQ800	YES	8	8	8	8	8	5	10	1	YES	690mA
IQ1000	YES	10	10	10	10	10	5	12	1	YES	870mA
IQ1200	YES	12	12	12	12	12	5	14	1	NO	950mA

*Note: IQ20 not upgradeable, color difference indicates upgrade path from either IQ 200 or IQ 400.

Upgrade Modules:

PCSC Add-on boards incorporate the PCSC Upgrade BUS, a ribbon cable connector, enabling TTL level communications from IQ series controllers and modular add-on configurations. The BUS enables IQ series controllers the ability to increase capacity and functionality depending on the specific Add-on adapter. It also enables your investment to be utilized with not yet developed controllers the ability to adapt to new technologies.

Model	Reader Ports	Relay Output	Door Status	REX	Voltage Output	Inputs	Upgrade Capable	Power Consumption
8U	8	8	8	8	8	-	YES	610
4U	4	4	4	4	4	-	YES	430
ALM	-	-	-	-	-	16	YES	90
OUT	-	16	-	-	-	16	YES	510
SAM	-	-	-	-	-	8	YES	170

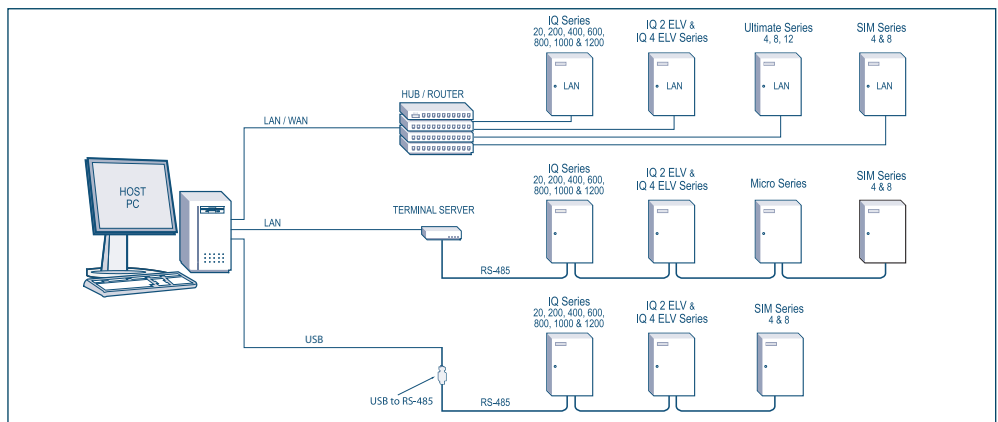

IQ-1215